



XC908-EV

ELECTRIC COMPACT WHEEL LOADER



Operating Weight **2835kg**

Bucket Capacity **0.4m³**

Rated Power **19kW**



MAIN SPECIFICATIONS

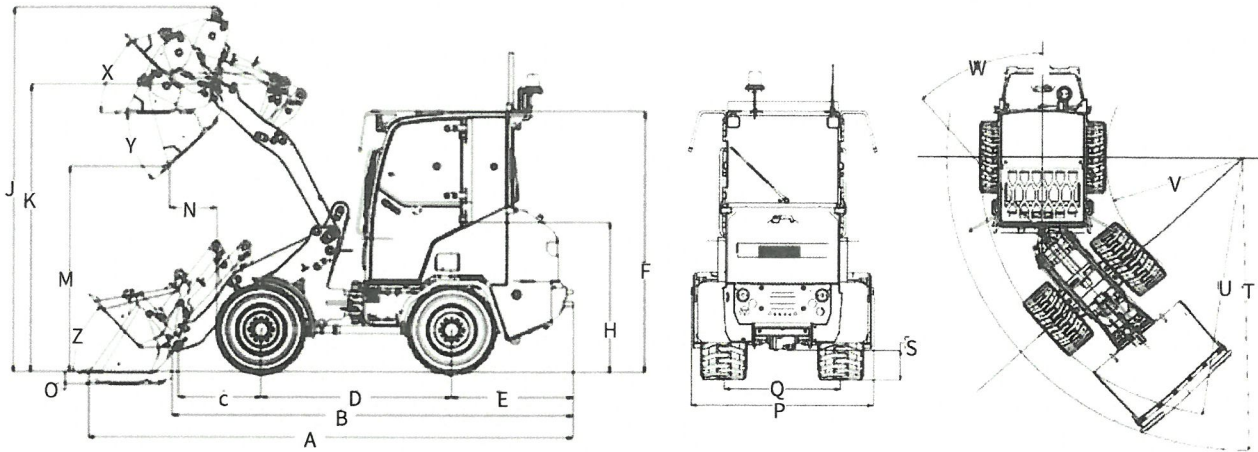

	Dimension and Specification	Parameter
A	Overall length	4305 mm
B	Overall length (without bucket)	3537 mm
C	Distance: center of front axle to bucket pin	737 mm
D	Wheelbase	1700 mm
E	Length rear: axle to bumper	1081 mm
F	Height to the top of cab	2315 mm
H	Seat height	1336 mm
J	Overall working height	3231 mm
K	Height to hinge pin, fully raised	2550 mm
L	Bucket leveling height	2295 mm
M	Dumping height	1828 mm
N	Dumping reach	410 mm
O	Digging depth	104 mm
P	Overall width	1578 mm
Q	Wheel track	1015 mm
S	Ground clearance	256 mm
T	Turning radius: over bucket	3419 mm
U	Turning radius: over tyres	2923 mm
V	Turning radius: inside of tyre	1506 mm
W	Steering angle	42°
X	Rollback angle at full lift	45°
Y	Dumping angle at full lift	43°
Z	Rollback angle, ground	41°

- The technology of XCMG electric compact wheel loaders is subject to constant improvement and upgrading. In case the specifications or detailed appearance contained in this brochure differ from actual products, the latter shall prevail.
- XCMG reserves the right of final interpretation for the above. Our products may be modified without prior notice to users.

Overall Parameter

Item	Parameter
Operating Weight	2835 kg
Bucket Capacity	0.4 m ³
Rated Load	800 kg
Max. Breakout Force	25 kN
Tipping Load	≥2027 kg
	≥1647 kg

Battery & Motor

Overall Voltage	76.8 V
Max. Rated Output Power	19 kW
Max. Rated Output Torque (Travel)	52 N·m
Battery	LFP Battery
Battery Capacity	20.5 / 26.5 kWh
Battery Voltage	76.8 V
Dc Charging Power	12 kW
Ac Charging Power	6 kW
Electrical System Voltage (low)	12 V
Charging Pile	12/6/3.2/2 kW
Battery Capacity-Charging Time	20.5 kWh-1.2/3.1/5.8/9.2 h
	26.5 kWh-1.5/3.9/7.5/11.8 h

Working Hydraulic System

Type	Constant pressure hydraulic system
Pump	Gear pump
Rated Flow	45 L/min
Control Valve	Third function multiway valve
System Pressure	18.5 MPa
Operating Hydraulic Circuit	Lifting circuit for lifting, holding, lowering and staying movable status of the boom. Tipping cylinder circuit for returning, holding and tipping the bucket
Total Circle Time	≤9 s

Braking System

Service Brake	Hydraulic power brake
Parking Brake	Mechanical parking brake
Emergency Brake	Emergency stop inside the cab



SOLID TO SUCCEED

XCMG European Sales and Services GmbH

Europark Fichtenhain B4, 47807 Krefeld, Germany

Email : info@xcmg-ess.de



WWW.XCMGGLOBAL.COM
XCMG OFFICIAL WEBSITE